

**OLYMPUS**<sup>®</sup>

Your Vision, Our Future

System Microscope

**BX63/BX53**

BX3 Series

**MACROSEARCH**  
YOUR SINGLE SOURCE OF PATHOLOGY AND MICROSCOPY

Move Your Imaging Forward





## Setting a New Standard in Accuracy and Efficiency

Choose the model you need with the motorization components you want. The combination of leading-edge imaging capabilities with the flexibility to customize the system to your specific application makes BX3 series microscopes powerful research tools.

With outstanding performance in fluorescence, brightfield, and darkfield imaging, BX3 series microscopes are easy to use and designed to meet the needs of researchers conducting routine through advanced imaging.



# User-Friendly Design for an Efficient Workflow

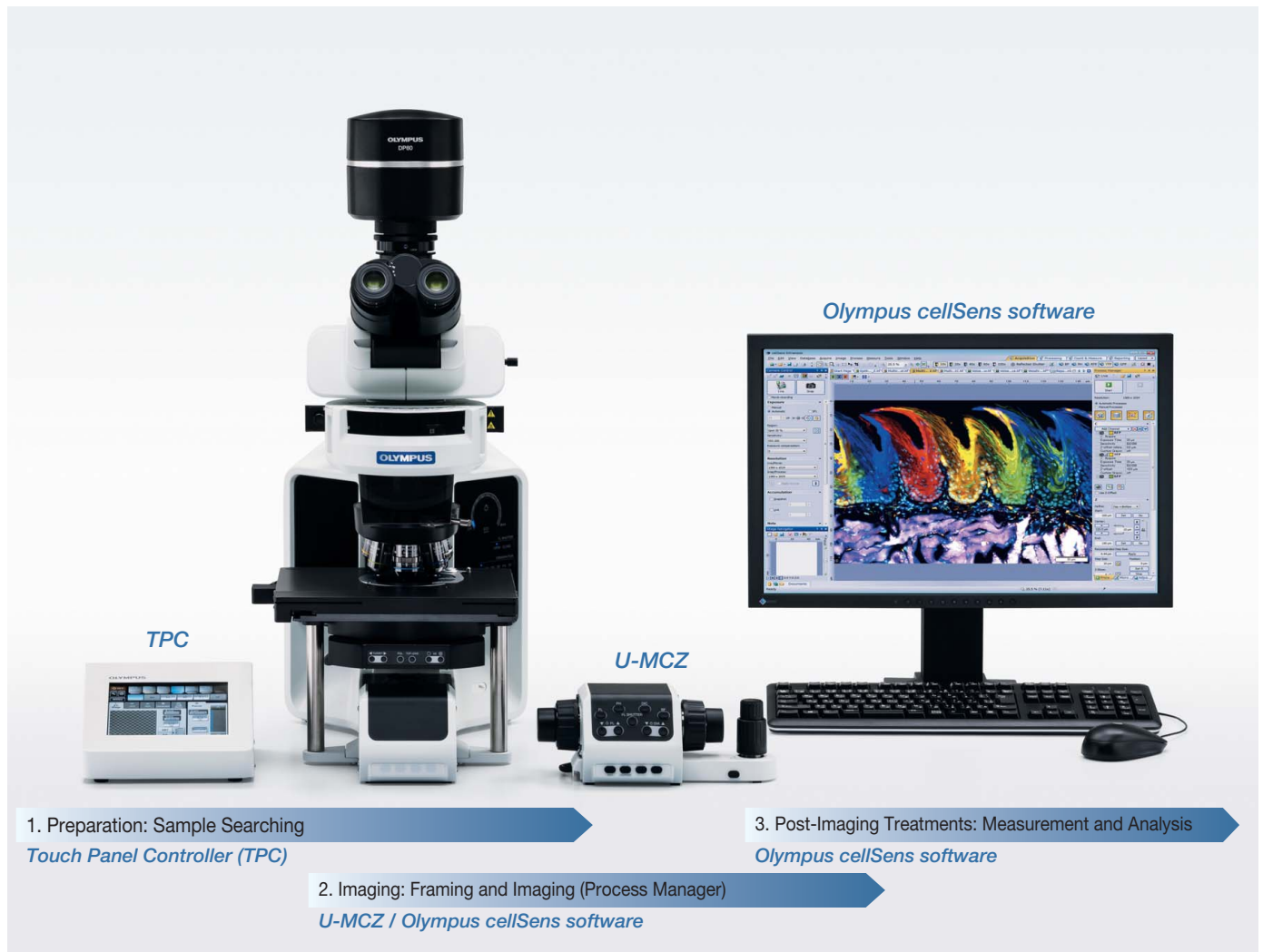

Bench space is at a premium in most labs. Fortunately, the BX63 microscope with Olympus cellSens imaging software offers flexibility to suit the way you work. Position the microscope on your bench and then place the touch panel and remote microscope controller where it's convenient—you don't need to sit directly in front of the microscope to control it.

The cellSens process manager automates multicolor, multipoint, and other imaging methods entered through the touch panel or directly into the software. After image acquisition, use cellSens software for processing, measurement, and analysis.

## One-Click Imaging



### Microscope Controls at Your Fingertips

With the touch panel controller, switch between different observation methods and magnifications with just a touch. The controller has two modes: guidance mode enables users to navigate the procedures currently in use while full operations mode provides access to the entire range of settings. With these modes, you can simplify operation to focus on just the settings you need for the application or take full control over the microscope. Multiple observation points and conditions can be saved in advance, so users can quickly recall previously used imaging conditions.

### Familiar Focusing and XY Stage Controls

The stage controller (U-MCZ) can be detached from the microscope frame and positioned where it's convenient for the user. When used in combination with the XY controller provided with our precision ultrasonic stage, it creates a user-friendly workflow with an operation that mimics how a manual focusing stage works. For added convenience, switches are located in the controller to enable changing between different observation methods, objectives, and mirror units while maintaining the ability to simultaneously select intensity adjustments or image capture.

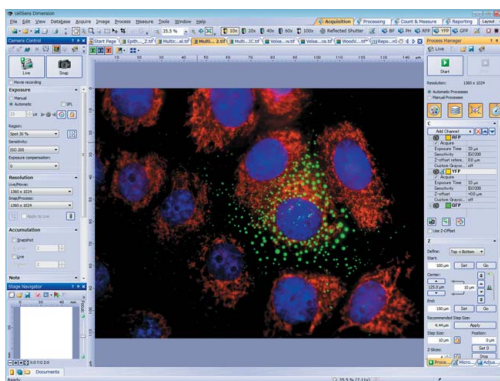

### Fast, Efficient Image Capture with the cellSens Process Manager and Workflow Optimization

Observation condition data can be entered into the touch panel and XY controller and then automatically transferred to cellSens imaging software. The process manager enables multichannel image acquisition to be fully automated.



### Instantly Switch Between Color and Monochrome with the DP80 Camera

The DP80 camera has two CCD sensors, so users can quickly switch from monochrome to color imaging without changing cameras. Get stunning color images of your sample or acquire quantitative information, such as intensity data, from the same camera. With the DP80 camera, highly sensitive fluorescence images and high-definition brightfield images are both easy to acquire.

# Simplify Your Workflow

## Advanced Optical Technology and User-Friendly Software

Advances in optics and microscopy have made it easier for users to capture high-quality images. With customizable workflows, cellSens imaging software makes the process even more efficient and helps users generate good data. Our leading-edge microscopy technology helps you see more while cellSens software helps you analyze it.

Solution	Each cellSens Package can be expanded towards a specific application by using optional "Solutions"
<b>Dimension</b>	available following solutions:
CI Deconvolution	Multiposition Well Plate Navigator Count & Measure
Ratio/FRET	Database Core Database Client NetCam
Photo Manipulation	
<b>Standard</b>	available following solutions:
Multichannel Acquisition	Manual Process Database Core Database Client
NetCam	Confuency Checker
<b>Entry</b>	available following solution:
Database Client	

## Straightforward Imaging with the Process Manager

### Multichannel

**Dimension** or **Standard** + **Multichannel Acquisition**

Use the touch panel controller to select your observation conditions and the system automatically switches filters and acquires the images. When used with the system's multipoint capability, users can automatically acquire multichannel images over a large area.

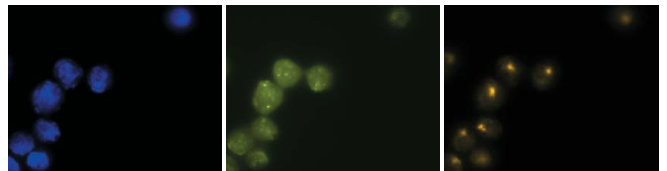

Multichannel imaging with switched excitation.

### Z-Stack

**Dimension**

The Z-stack mode enables images to be captured along the Z-axis at a specific focus to create a maximum intensity projection—a sharp, all-in-focus image. Use the controller (U-MCZ) to check the upper and lower focus limits of a specimen, register those positions, and the system does the rest.

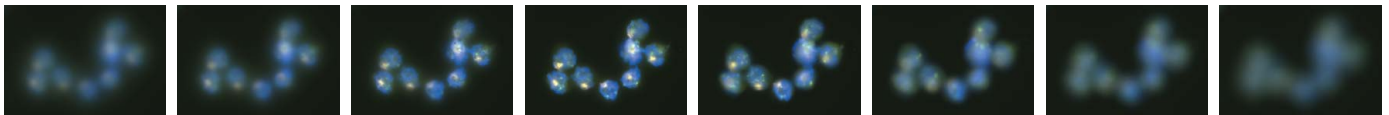

Z-stack imaging: the same image is captured at different levels in the Z-plane.

### Panoramic Imaging

**Dimension** + **Multiposition**  
**Standard** + **Manual Process**

The manual Multiple Image Alignment (MIA) function creates a single image while the specimen is being scanned. Images from adjoining sections of the sample can be combined into a single panoramic image. With cellSens Dimension software's multiposition solution and a motorized system, wide area imaging can be completely automated.

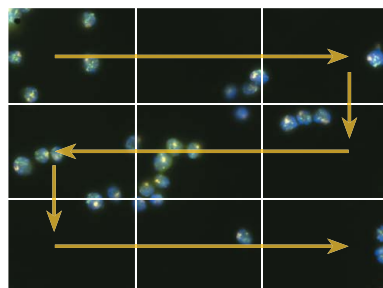

Images are accurately stitched together to create panoramic images.

### Maximum Intensity Projection

The Maximum Intensity Projection mode creates a sharp, final all-focus image for thicker specimens.

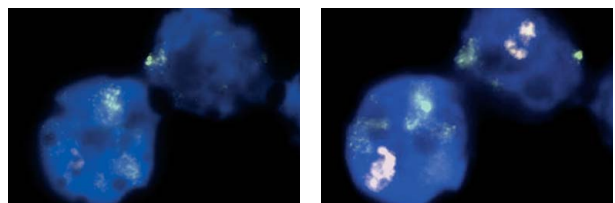

Original Image

Composite Image

Maximum Intensity Projection: Composite Image Produced by Selecting the Brightest Signals from Multiple Images on the Z-Plane.

\* cellSens software is not for clinical diagnostic use

## Experiment Manager

### Graphical Experiment Manager (GEM)

Dimension

The GEM uses a simple drag-and-drop interface to build simple or complex experiments in cellSens software. Actions can be combined in specific frames to dictate a specific order of operation and the priority of automation and imaging.

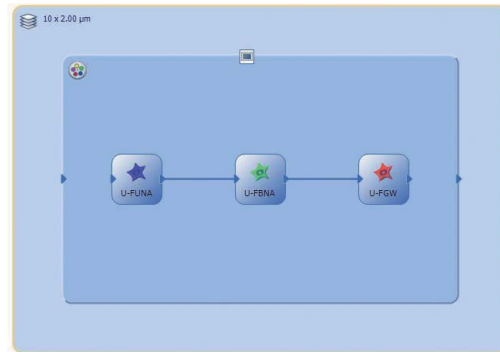

## Measurement and Analysis

### Manual Measurement

Dimension

Standard

Entry

The measurement tools in cellSens software make it easy to measure the distance between points, areas, intensity levels, and morphological parameters. Measurement data is saved as an image layer that can be exported to Microsoft Excel software and cellSens workbook formats. The data can also be viewed using OlyVIA image viewer, a free software program for PC and IOS devices that enables you to view your microscope images while on the go.

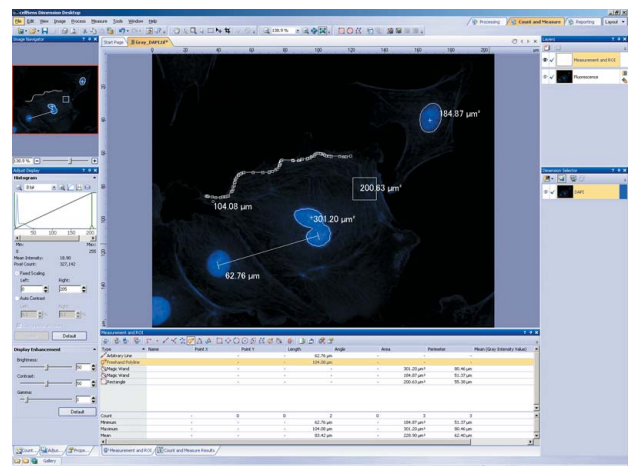

### Automated Object Measurement and Classification

Dimension

+ Count & Measure

The Count & Measure solution delivers efficient, precise object detection for automated nuclei counting and classification and expands the set of manual measurements in cellSens software. This solution automates the normally tedious task of measuring and classifying objects. Easily perform automatic object measurement and classification using an interactive interface where objects are always linked with their measurements.

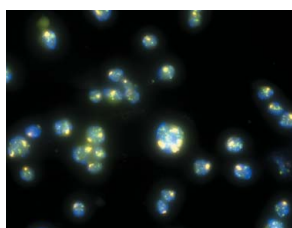

Original Image

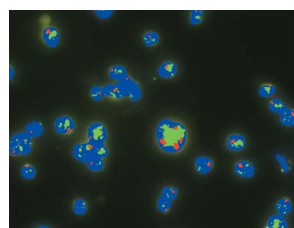

Object Detected on Image

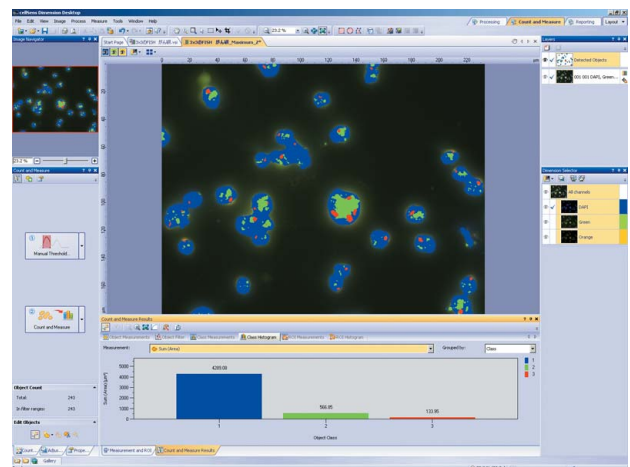

Measurement and Classification Results

## See Only What You Want in Fluorescence Imaging

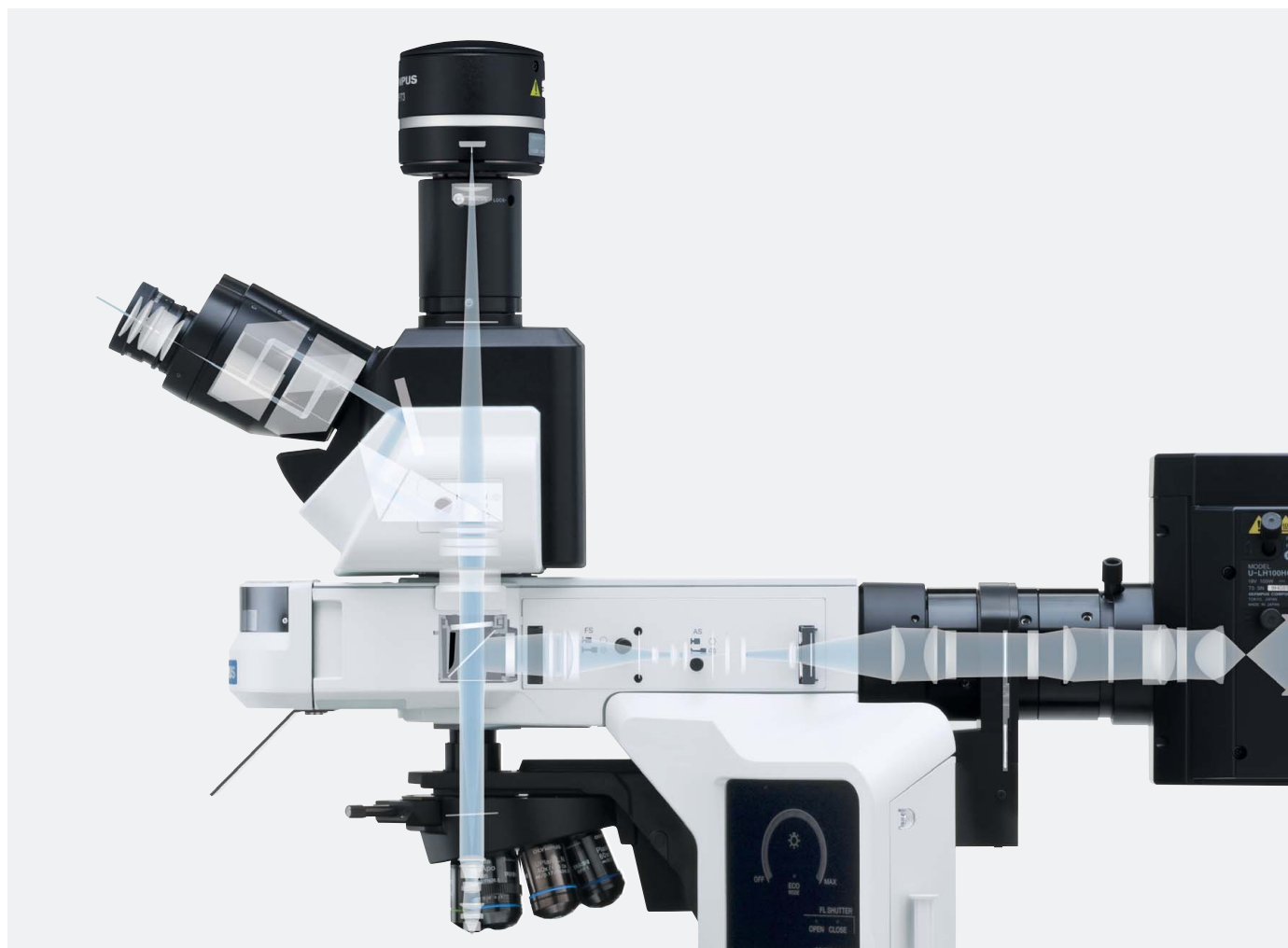

The BX3 series' improved signal-to-noise ratio yields brighter fluorescence images. The combination of narrow band filter cubes, high signal-to-noise ratio mirror units, high-transmission objectives, and fluorescence illuminators with a fly-eye lens system deliver bright, uniform illumination and improved detection.

# Get Better Fluorescence Data



### Uniform Fluorescence Illumination via a Fly-Eye Lens System

Fluorescence illuminators equipped with a fly-eye lens system (BX3-RFAA and BX3-RFAS) provide uniform illumination, enabling better post-acquisition enhancement and processing.

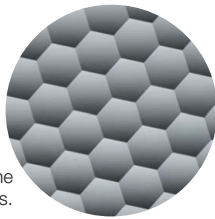

Enlarged image of the surface of a fly-eye lens.

### Optimized Fluorescence Mirror Units

With the latest coating technology, our mirror units achieve outstanding performance for higher transmissions, sharper cut-offs, and efficient fluorescence detection.



### More Options with an 8-Position Illuminator

Add flexibility to your fluorescence imaging with our 8-position illuminator and easily interchangeable mirror units. More positions mean researchers don't have to replace mirror units for multichannel or FISH applications, saving time.

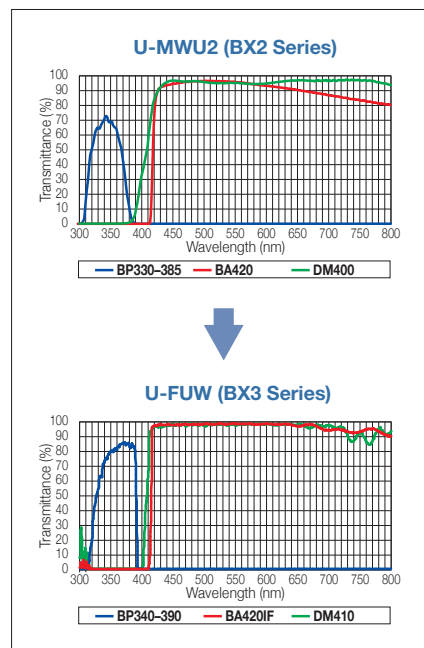

### Mirror Units Minimize Stray Light

All mirror units have a low reflection function that reduces scattered light for a higher signal-to-noise ratio.

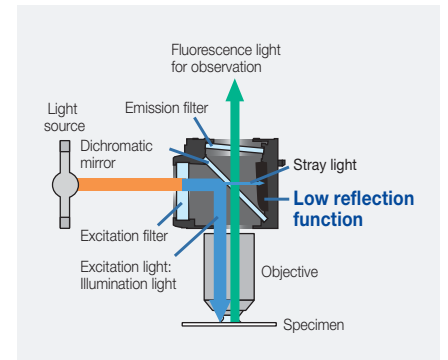

### Detect Subtle Fluorescence Emissions with Weak Excitation Light

Olympus UIS2 objectives are made with low autofluorescence glass, anti-reflection coatings, and lens joining materials for an improved signal-to-noise ratio. The result is that users can more easily detect subtle fluorescence emissions with weak excitation light.



### Condenser Reduced Back-Reflection

The motorized universal condenser is designed to reduce back-reflections and autofluorescence by swinging its top lens out, automatically closing the diaphragm to the minimum, and moving the wheel between two positions during fluorescence imaging.



### Low Autofluorescence Immersion Oil

While some immersion oil can cause unwanted light emissions, our oil is specially designed to reduce autofluorescence.



## Fully Motorized and Easy to Use



Intelligent Microscope BX63  
+ Digital Camera DP80  
+ cellSens software

We designed the BX63 microscope based on feedback from hundreds of researchers and microscope users. The result is a fully motorized system that delivers flexibility and ease of use to researchers. Position the convenient touch panel controller where it's comfortable for you and maintain control of the entire system with just a simple touch, or control the system via a PC with cellSens imaging software. If you're using both, all data entered via the controller is automatically transferred to cellSens software. From image capture to final reporting, the combination of a BX63 microscope and cellSens software delivers power and convenience.

# BX63

\* cellSens software is not for clinical diagnostic use

### Image Quality You Can Count On

The pairing of the system's motorized nosepiece focusing system and fixed stage helps eliminate sources of vibration for high-quality image acquisitions.

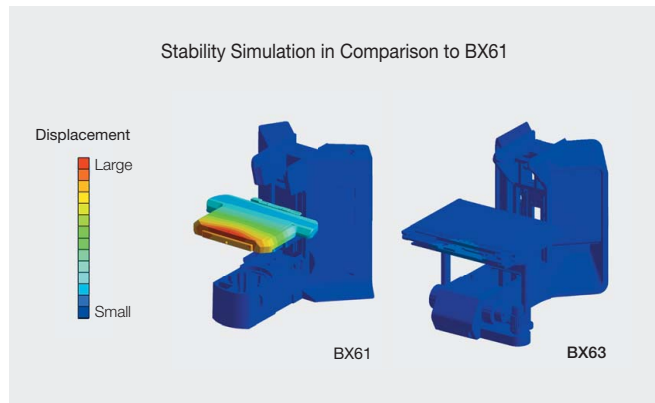

### Save Time with a Motorized Focus

The high-speed, precision focusing nosepiece has 0.01  $\mu\text{m}$  resolution and 20 mm vertical stroke. Users can program a Z-stack and focus control to save time during their observations. The field diaphragm adjustment for transmitted light is also motorized.



### Fast Fluorescence Imaging

The flexibility of the motorized fluorescence illuminator (BX3-RFAA) accommodates multichannel observations of specimens. The 8-position mirror unit makes it quick and simple to change fluorescence wavelengths.



### Quickly Adjust the Intensity of Fluorescence and Transmitted Light

The motorized neutral density (ND) filter wheel (U-AW) makes it easy to adjust the intensity of fluorescence and transmitted light. Special adaptors are required for mounting (U-LHEAD for fluorescence and U-LH100ADP for transmitted light).



### Continuous Observations from Low to High Magnifications

Users can attach seven objectives to the motorized nosepiece, enabling continuous observations from low to high magnifications. Users also have the flexibility of attaching specialized objectives, such as for polarized light observations.



### Flexible Observation Options

By integrating with designated optical components, the motorized universal condenser (BX3-UCD8A) accommodates various transmitted light observation techniques, including brightfield, differential interference contrast (DIC), and phase contrast.



### Precision XY Control

The ultrasonic stage (BX3-SSU) delivers precision XY control. The XY controller can be mounted on the focus controller (U-MCZ) for the BX63 microscope and worked like conventional stage handles.



## Flexible and Fully Customizable



The versatile BX53 microscope can be configured to meet the needs of your research. It supports a wide range of fluorescence imaging applications and has a range of advanced features to streamline your workflow. Motorized versions of most components are available, so you can configure the system the way you want it.

# BX53

**Customizable Control Layout**

The BX53 microscope enables operators to create customized working environments. Light intensity can be controlled via the dial in front. The detachable fine focus handle can be positioned on either side of the microscope, depending on operator preference.



**Easily Image Specimens with Multiple Labels**

The 8-position fluorescence illuminator enables flexible responses to various fluorescence specimens. The mirror units are easy to change.



**Automatically Switch DIC Prisms**

When you change objectives on the motorized or coded 7-position revolving nosepiece, integrated with the motorized universal condenser, the system switches to the optimal DIC prism for faster observations.

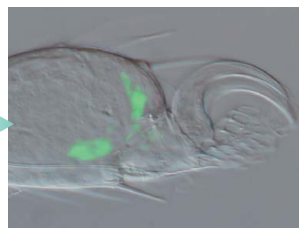

With a coded nosepiece, when you change objectives, the DIC prism automatically switches over.

Optimal Contrast Observation

**Quickly Change Observation Methods**

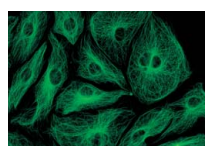

Fluorescence

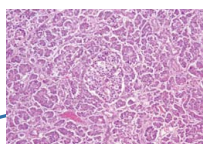

Brightfield

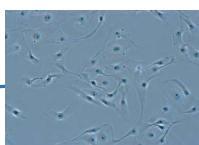

Phase Contrast

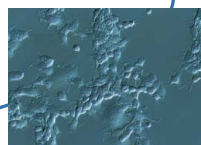

Nomarski DIC

**Consistent Brightness when Changing Magnifications**

The BX3 series' light intensity manager eliminates the step of adjusting lamp brightness when changing magnification. By maintaining uniform brightness at any magnification, users can achieve their observations quickly and with reduced eye strain.

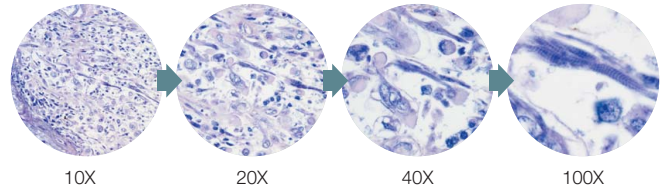

**Coded Units to Save Imaging Settings**

Olympus' cellSens imaging software integrates with coded and motorized microscope components to automatically store fluorescence mirror unit and objective data along with the images, facilitating post-image analysis.

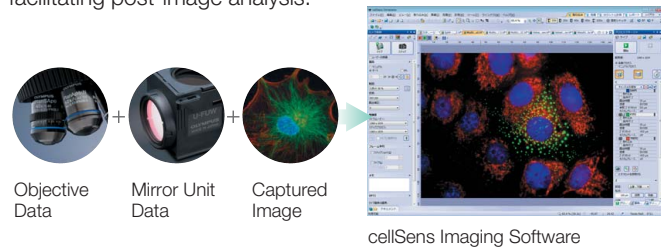

cellSens Imaging Software



System Microscope BX53

# Get Optimal Performance Across a Wide Wavelength Spectrum



**UIS2**  
World-leading optics

## UPLSAPO Series

Thanks to our original multi-coatings, our Super Apochromat objectives compensate for spherical and chromatic aberrations from the UV to the near infrared region. The objectives' sensitivity to fluorescence emissions enables the acquisition of sharp, clear images without color shift, even in brightfield and Nomarski DIC observations. For quality and performance, these objectives are suitable for digital imaging.

# Objectives



UIS2 objectives

Objective	NA	W.D. (mm)	FN	Cover glass thickness (mm)	Immersion	Spring	Cor-rection ring	Iris dia-phragm	Water proof and oil proof function
UPLSAPO 4X	0.16	13	26.5	—					
UPLSAPO 10X2	0.40	3.1	26.5	0.17					
UPLSAPO 20X	0.75	0.6	26.5	0.17		✓			
UPLSAPO 20X0	0.85	0.17	26.5	—	Oil	✓			✓
UPLSAPO 30XS	1.05	0.8	22	0.13-0.19	Silicone		✓		✓
UPLSAPO 30XSIR	1.05	0.8	22	0.13-0.19	Silicone		✓		✓
UPLSAPO 40X2	0.95	0.18	26.5	0.11-0.23		✓	✓		
UPLSAPO 40XS	1.25	0.3	22	0.13-0.19	Silicone	✓	✓		✓
UPLSAPO 60XW	1.20	0.28	26.5	0.13-0.21	Water	✓	✓		✓
UPLSAPO 60X0	1.35	0.15	26.5	0.17	Oil	✓			✓
UPLSAPO 60XS2	1.30	0.3	22	0.15-0.19	Silicone	✓	✓		✓
UPLSAPO 100X0	1.40	0.13	26.5	0.17	Oil	✓			✓
UPLSAPO 100XS	1.35	0.2	22	0.13-0.19	Silicone	✓	✓		✓
UPLSAPO 100XOPH	1.40	0.12	26.5	0.17	Oil	✓			✓
PLAPON 1.25X	0.04	5	26.5	—					
PLAPON 2X	0.08	6.2	26.5	—					
PLAPON 60X0	1.42	0.15	26.5	0.17	Oil	✓			✓
PLAPON 60XOSC2	1.40	0.12	22	0.17	Oil	✓			✓
PLAPON 60XOPH	1.42	0.15	26.5	0.17	Oil	✓			✓
UPLFLN 4X	0.13	17	26.5	—					
UPLFLN 10X2	0.30	10	26.5	—					
UPLFLN 20X	0.50	2.1	26.5	0.17		✓			
UPLFLN 40X	0.75	0.51	26.5	0.17		✓			
UPLFLN 40X0	1.30	0.2	26.5	0.17	Oil	✓			✓
UPLFLN 60X	0.90	0.2	26.5	0.11-0.23		✓	✓		
UPLFLN 60X0I	1.25-0.65	0.12	26.5	0.17	Oil	✓		✓	✓
UPLFLN 100X02	1.30	0.2	26.5	0.17	Oil	✓			✓
UPLFLN 100X0I2	1.3-0.6	0.2	26.5	0.17	Oil	✓		✓	✓
UPLFLN 10X2PH	0.30	10	26.5	—					
UPLFLN 20XPH	0.50	2.1	26.5	0.17		✓			
UPLFLN 40XPH	0.75	0.51	26.5	0.17		✓			
UPLFLN 60X0IPH	1.25-0.65	0.12	26.5	0.17	Oil	✓		✓	✓
UPLFLN 100X02PH	1.30	0.2	26.5	0.17	Oil	✓			✓

Objective	NA	W.D. (mm)	FN	Cover glass thickness (mm)	Immersion	Spring	Cor-rection ring	Iris dia-phragm	Water proof and oil proof function
UPLFLN 4XP	0.13	17	26.5	—					
UPLFLN 10XP	0.30	10	26.5	—					
UPLFLN 20XP	0.50	2.1	26.5	0.17		✓			
UPLFLN 40XP	0.75	0.51	26.5	0.17		✓			
UPLFLN 100XOP	1.30	0.2	26.5	0.17	Oil	✓			✓
PLFLN 100X	0.95	0.2	26.5	0.14-0.2		✓	✓		
PLN 2X	0.06	5.8	22	—					
PLN 4X	0.10	18.5	22	—					
PLN 10X	0.25	10.6	22	—					
PLN 20X	0.40	1.2	22	0.17		✓			
PLN 40X	0.65	0.6	22	0.17		✓			
PLN 50X0I	0.90-0.50	0.2	22	—	Oil	✓		✓	✓
PLN 100X0	1.25	0.15	22	—	Oil	✓			✓
PLN 10XPH	0.25	10.6	22	—					
PLN 20XPH	0.40	1.2	22	0.17		✓			
PLN 40XPH	0.65	0.6	22	0.17		✓			
PLN 100XOPH	1.25	0.15	22	—	Oil	✓			✓
PLN 4XP	0.10	18.5	22	—					
LPLN40X	0.6	3.4-4.1	22	0-1			✓		
ACHN 10XP	0.25	6	22	—					
ACHN 20XP	0.40	3	22	0.17					
ACHN 40XP	0.65	0.45	22	0.17		✓			
ACHN 100XOP	1.25	0.13	22	—	Oil	✓			✓
MPLAPON 60X	0.90	0.4	26.5	0		✓			
MPLAPON 100X	0.95	0.3	26.5	0					
MPLAPON 100X0	1.40	0.1	26.5	0	Oil	✓			✓
MPLFLN 2.5X	0.08	10.7	26.5	—					
MPLFLN 10X	0.30	11	26.5	—					
MPLFLN 20X	0.45	3.1	26.5	0					
MPLFLN 40X	0.75	0.63	26.5	0					
MPLFLN 100X	0.90	1	26.5	0					
MPLN 5X	0.10	20	22	—					
UAPON 20XW340	0.70	0.35	22	0.17	Water	✓			✓
UAPON 40X0340-2	1.35	0.1	22	0.17	Oil	✓			✓
UAPON 40XW340	1.15	0.25	22	0.13-0.25	Water	✓	✓		✓

**UPLFLN (UPLFLN-PH) Series**

These Plan objectives provide flat images with high transmission up to the near-infrared region of the spectrum. With their high signal-to-noise ratio, excellent resolution, and high contrast images, the objectives are especially effective in brightfield and Nomarski DIC observations. The UPLFLN-PH series is optimized for phase contrast observation.



**PLAPON Series**

Designed for excellent resolution and contrast, Plan Apochromat objectives reduce chromatic aberration to low levels. The PLAPON60XOSC objective has improved chromatic aberration compensation at 405–650 nm and improved image-forming performance at 405 nm.



**PLN Series**

Appropriate for a range of biological applications, these high-quality objectives offer excellent flatness up to FN 22 in transmitted brightfield (phase contrast) observation. The PLN-PH series is designed for phase contrast observation.



# Renowned Optical Performance in Various Observation Methods

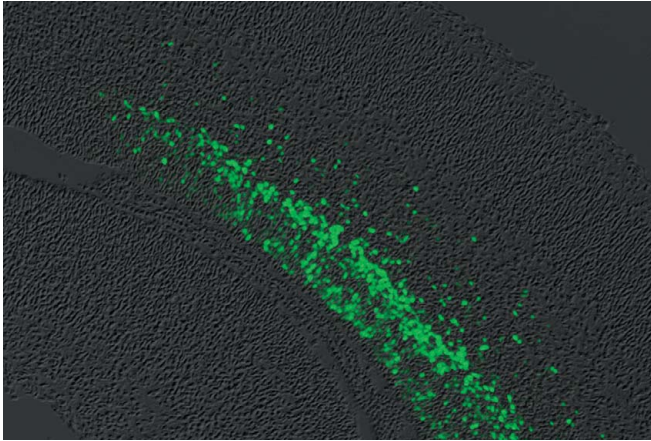

Brain Section of Mouse at Embryonic Day 15 (GFP)

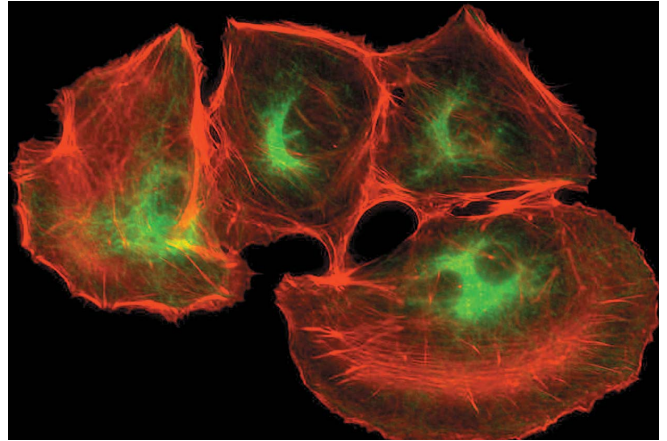

NRK-52E Cells (Alexa Fluor 488/Alexa Fluor 546)

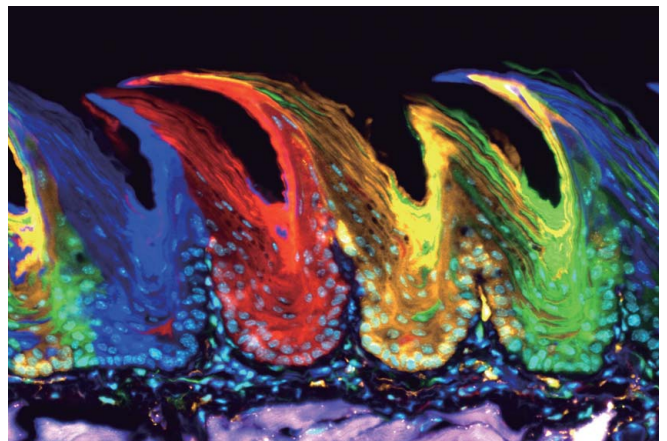
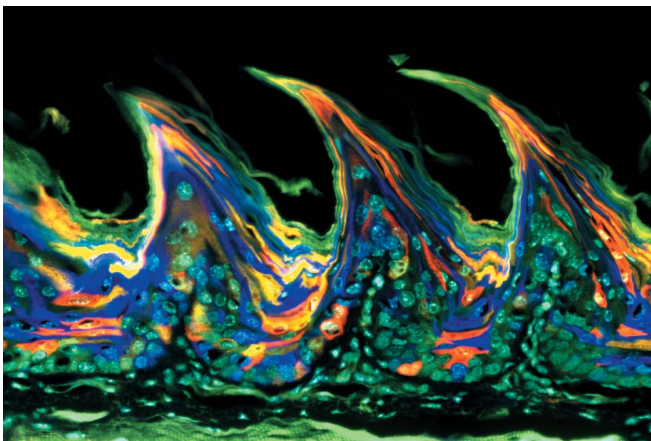

Rainbow mouse (each interpapillary pit of the tongue is occupied by single-color cells that originate from monoclonal stem cells). Two days after tamoxifen induction, the epithelial cells in the interpapillary pit express random colors, indicating that multiple clones proliferated independently. However, after 84 days, each interpapillary pit was occupied by single-color cells, indicating that they are derived from monoclonal stem cells. (Nature Cell Biology 15, 511–518, 2013)

## Fluorescence

### Outstanding Fluorescence Imaging

The light source (U-HGLGPS) is a pre-centered light guide illuminator that is equipped with a liquid light guide that suppresses the impact of heat generated from the lamp on both the microscope and specimens. Utilizing a high-pressure mercury bulb, the light source has an average lifetime of 2,000 hours and stable, even illumination.



U-HGLGPS (Light Guide Illumination System)

Three types of reflected illuminators are available: motorized (BX3-RFAA), coded (BX3-RFAS), and a universal reflected illuminator (BX3-URA). When using the coded or motorized fluorescence illuminator with cellSens software, fluorescence mirror unit data can be stored with the images.



# Observation Methods



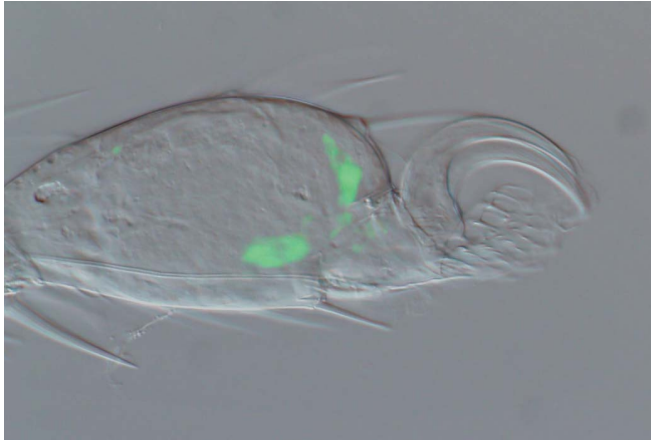

Distal Tip of a *Drosophila* limb (GFP)

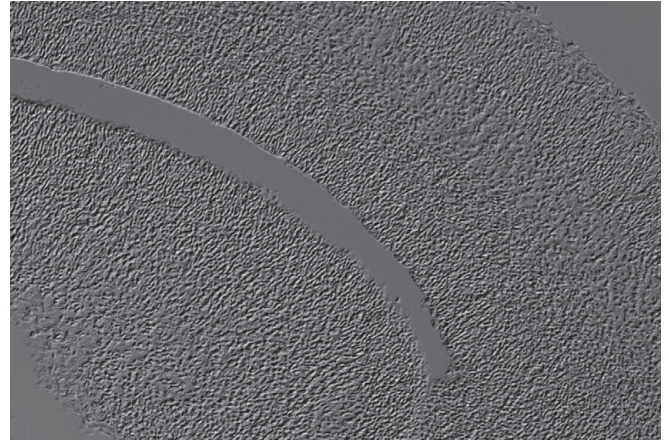

Brain Section of Mouse at Embryonic Day 15

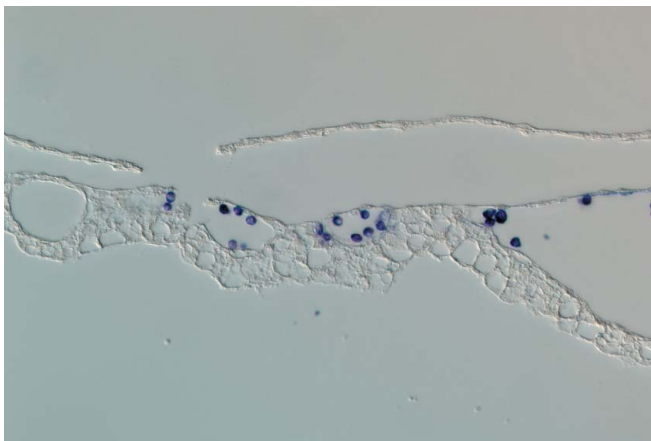

Blood Island at Stage 12 of Chicken Development

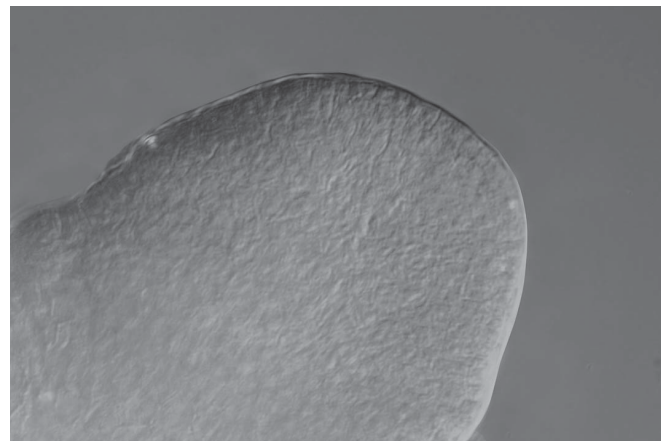

A Shoot Apical Meristem of Rice

## Nomarski DIC

### Images Optimized to Your Specimen's Characteristics

Olympus offers a wide selection of DIC sliders with different shearing values for acquiring optimal specimen images. The U-DICT and U-DICTS sliders are designed for excellent all-around performance while the U-DICTHC is optimized for high-contrast observations of thin specimens and the U-DICTHR is optimized for high-resolution, reduced glare observations of thick specimens.



① U-DICT ② U-DICTS ③ U-DICTHR ④ U-DICTHC

Two condensers are also available: an 8-position universal condenser (U-UCD8-2) and a motorized universal condenser (BX3-UCD8A). Both condensers can be used for a range of observation methods, including brightfield, darkfield, phase contrast, DIC, and simple polarized light.



## Brightfield

### Get Bright Images with Excellent Resolution/Flatness at All Magnifications

A diverse condenser lineup for brightfield applications includes an achromatic applanatic condenser (U-AAC) that delivers excellent resolution and flatness from low to high magnifications, a swing-out condenser (U-SC3) that accommodates 1.25X to 100X objectives, a low magnification condenser (U-LC) for continuous 2X to 100X (dry) observation, and a condenser designed for ultra-low magnification (U-ULC-2).



① U-SC3 ② U-ULC-2 ③ U-AC2 ④ U-AAC ⑤ U-LC

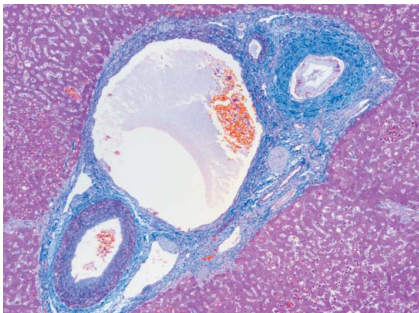

Liver (Azan Stain)

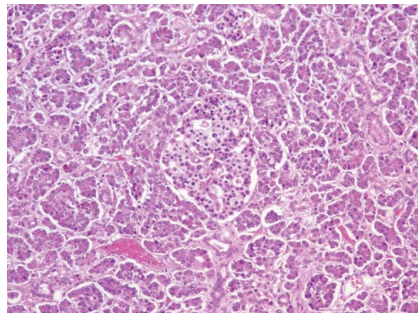

Pancreas (HE Stain)

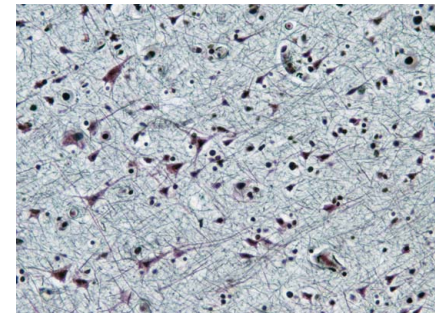

Cerebrum (Bodian Stain)

## Phase Contrast

### Outstanding Image Clarity

High contrast phase imaging enables close observation of a cell's interior and live bacteria. UPLFLN-PH or PLN-PH series objectives enable users to make observations from 10X all the way up to 100X magnification. With a phase/darkfield condenser (U-PCD2), users can view specimens in brightfield or darkfield. Simultaneous observation with reflected light fluorescence microscopy is also possible.



U-PCD2

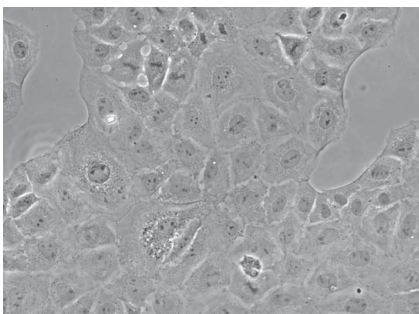

NRK-52E Cells

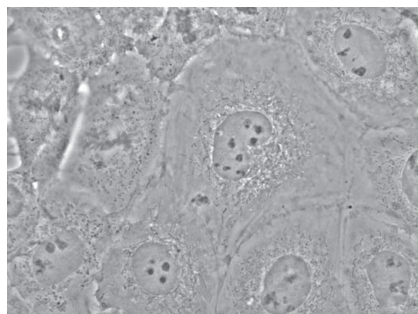

NRK-52E Cells

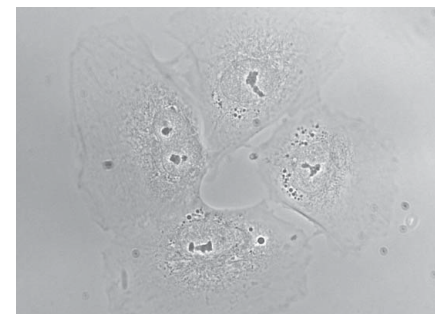

NRK-52E Cells

## Polarized Light

### Observe Tissue without Staining

Tooth, bone, muscle tissue, nerve tissue, actomyosin fibers, and mitotic spindles can all be observed without staining. There are available intermediate attachments (U-OPA/U-CPA) that facilitate orthoscopic and orthoscopic/conoscopic viewing. Various compensators make it possible to observe a wide range of retardation. A condenser specially designed for polarization is also available along with a revolving nosepiece, rotating stage, objectives, and simple polarizing attachment.



①U-POC-2 ②U-CPA ③U-OPA ④U-AN360P-2  
⑤U-P4RE ⑥U-GAN ⑦U-POT

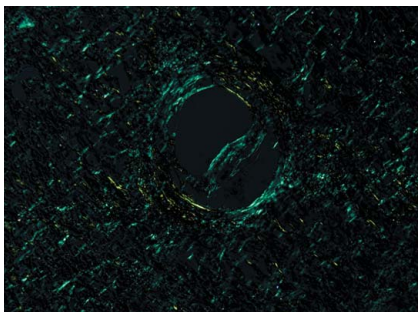

Amyloid



Asbestos



Urate crystals

## Darkfield

### High-Quality Darkfield Observations at Any Magnification

A dry darkfield condenser (U-DCD) for 10X to 100X magnification and an NA up to 0.8 and an oil immersion darkfield condenser (U-DCW) for 20X to 100X magnification and an NA of up to 1.2 are both available.

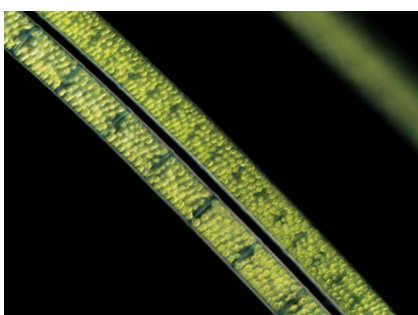

Spirogyra



Water Flea

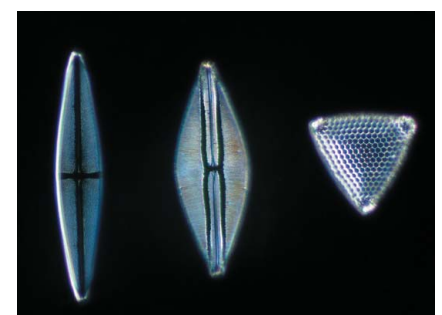

Diatom

# The Right Camera for Your Application

## Digital Cameras

### DP80 Dual CCD Camera

#### Leading-Edge Dual Sensor Camera for High-Quality Monochrome and Color Imaging

The DP80 camera enables both high-quality fluorescence image acquisition and high-quality brightfield imaging simply by switching between the two CCD sensors. This highly-sensitive monochrome CCD provides clear images of even dim fluorescent light, while the color CCD acquires brightfield images (up to 12.5 million pixels) with true-to-life color reproduction. The sensors are precalibrated, so users can easily superimpose color and monochrome images with pixel-to-pixel precision. The camera's outstanding imaging performance is an advantage when creating presentation or scientific publications.

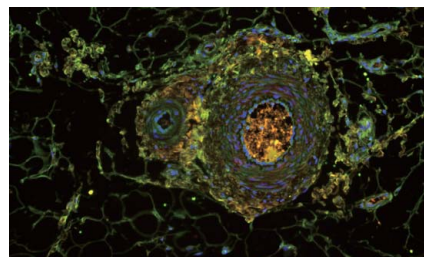

Captured by monochrome CCD with pseudo-colors

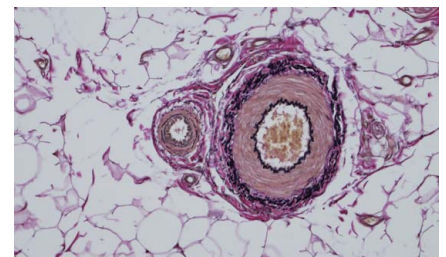

Captured by color CCD

### DP74 Color Fluorescence Camera

#### Increase the Speed of Your Imaging Workflow

The DP74 camera captures realistic, high-quality images and has features that enable users to easily make their observations. The position navigator helps keep track of a user's position in the sample so that they always know what they're imaging. A wide field of view enables operators to capture more of their sample in each image, while accurate color reproduction renders natural images of the specimen and works well with dim fluorescence. The camera can also follow the movement of the stage to create a real-time panoramic image with mapped zoom-outs, enabling fast sample documentation.



### DP27 Digital Camera

#### Capture Detailed Brightfield Images

With a 5.05-megapixel CCD, the DP27 camera captures images at up to 2,448 × 1,920 pixel resolution. For samples colored with the most commonly used stains, the camera provides excellent contrast. Large areas captured at a low magnification offer vivid clarity, even when enlarged several times. Precisely reproduced fine structures and subtle color differences enable targets on the monitor to be accurately identified, similar to looking through the observation tubes. The camera is available in a completely stand-alone configuration so it can be used without a PC.



\*DP series digital cameras are not for clinical diagnostic use

## DP22 Cost-Effective Camera

### Capture Clear Images for Presentations

The stand-alone DP22 camera provides accurate color representations of your sample for conferences and collaboration. The camera also has a cell culture mode. Used with phase contrast, the cell culture mode reduces halos, making it easier for users to check the health of their cell cultures. Optional cellSens software expands the camera's functionality.



## Accessories

### Camera Adaptors

The single port tube of the trinocular tube is detachable and can be used with various cameras through a range of adaptors.

Camera Adaptor (projection lens)	Projection Magnifications	Projection Area (FN)		
		2/3 in. CCD	1/2 in. CCD	1/3 in. CCD
U-TV1XC	1X	11	8	6
U-TV1X-2+U-CMAD3	1X	11	8	6
U-TV1X-2+U-BMAD	1X	11	8	6
U-TV0.63XC	0.63X	17.5	12.7	9.5
U-TV0.63XB	0.63X	17.5	12.7	9.5
U-TV0.5XC-3	0.5X	22	16	12
U-TV0.35XC-2	0.35X	—	22	17.1

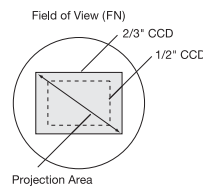

$$\text{Practical Field of View (mm)} = \frac{\text{Projection Area (field number)}}{\text{Objective Magnifications}}$$

### Eyepieces

Eyepieces maintain image flatness when a reflected light illuminator or other intermediate tube is attached. The two available types are FN 22 and FN 26.5.

Item	Name	FN	Diopter	Micrometer (omm)
Widefield	WHN10X	22		24
	WHN10X-H	22	-8 — +5	24
	CROSSWHN10X	22	-8 — +5	
Super widefield	SWH10X-H	26.5	-8 — +2	—
	MICROSSWH10X	26.5	-8 — +2	
	CROSSSWH10X	26.5	-8 — +2	



### Observation Tubes/Eyepoint Adjusters

A wide range of observation tubes are available for the BX3 series, including wide field binocular, trinocular types, various tilting tubes, tilting, telescopic, lifting binocular tubes, and tubes for observing upright images where the specimen and the observed image move in the same direction.

- ①U-TTBI/U-ETBI ②U-TTLBI ③U-TTR-2 ④U-SWETTR-5 ⑤U-BI30-2 ⑥U-TBI-3  
⑦U-TR30/U-TR30NIR ⑧U-SWTR-3 ⑨U-TBI-3-CLI ⑩U-ETR-4 ⑪U-EPA2 ⑫U-EPAL-2



# BX63 system diagram

◆ WHN10X-H, CROSS WHN10X  
Eyepieces  
U-CT30-2  
Centering telescope

\* WHN10X, WHN10X-H, CROSS WHN10X  
Eyepieces  
U-CT30-2  
Centering telescope

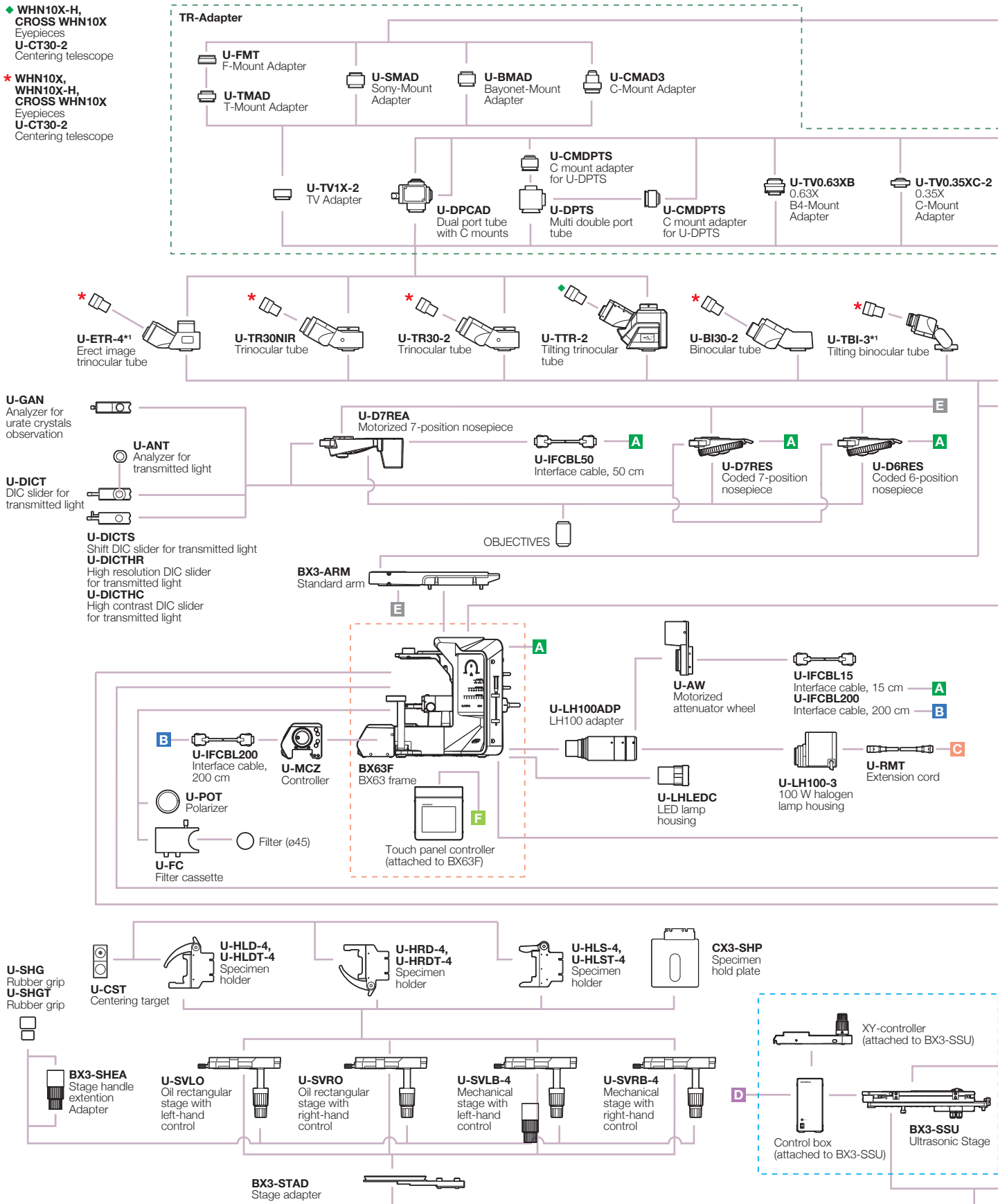

\*1 Slight vignetting may occur in combination with an additional intermediate attachment or fluorescence illuminator. \*2 Require an additional intermediate attachment or fluorescence illuminator.

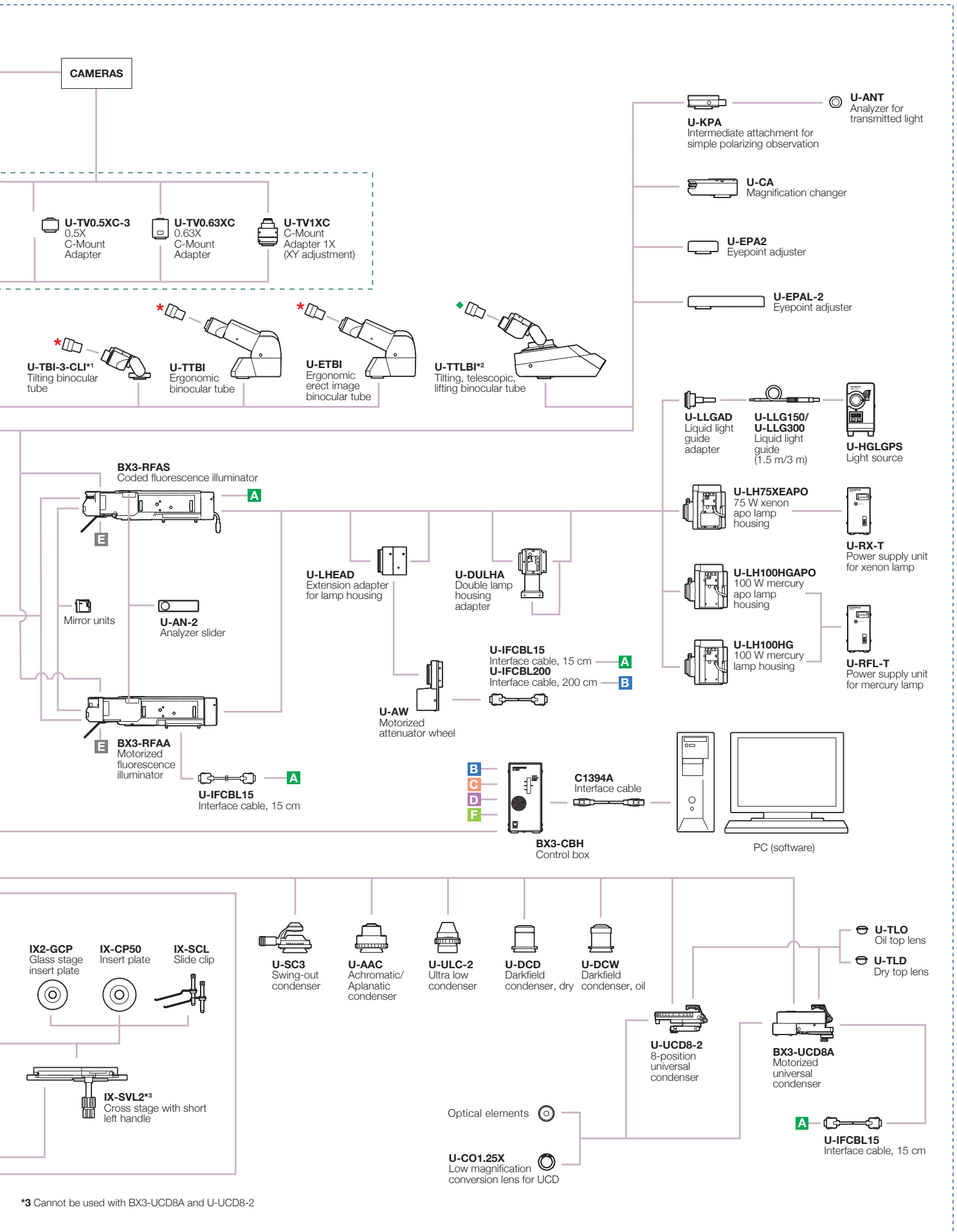

# BX53 system diagram

◆ **WHN10X-H, CROSS WHN10X**  
Eyepieces  
**U-CT30-2**  
Centering telescope

\* **WHN10X, WHN10X-H, CROSS WHN10X**  
Eyepieces  
**U-CT30-2**  
Centering telescope

▲ **SWH10X-H, CROSS SWH10X, MICRO SWH10X**  
Eyepieces  
**U-CT30-2**  
Centering telescope

## TR-Adapter



**U-SWETTR-5**  
Super widefield erect image tilting trinocular observation tube

**U-SWTR-3**  
Super widefield trinocular tube

**U-ETR-4\*1**  
Erect image trinocular tube

**U-TR30NIR**  
Trinocular tube

**U-TR30-2**  
Trinocular tube

**U-TTR-2**  
Tilting trinocular tube

**U-BI30-2**  
Binocular tube

**U-TBI-3\*1**  
Tilting binocular tube

**U-GAN**  
Analyzer for urate crystals observation

**U-ANT**  
Analyzer for transmitted light

**U-DICT**  
DIC slider for transmitted light

**U-DICTS**  
Shift DIC slider for transmitted light  
**U-DICTHR**  
High resolution DIC slider for transmitted light  
**U-DICTHC**  
High contrast DIC slider for transmitted light

**U-ANT**  
Analyzer for transmitted light

**U-TAD**  
Plate adapter

## COMPENSATORS

## OBJECTIVES

**U-D7REA**  
Motorized 7-position nosepiece

**U-D7RES**  
Coded 7-position nosepiece

**U-D6RES**  
Coded 6-position nosepiece

**U-D7RE**  
Septuple revolving nosepiece for DIC/simple POL

**U-D6RE**  
Sextuple revolving nosepiece for DIC/simple POL

**BX3-ARM**  
Standard arm

**BX53F2**  
BX53 frame

**U-POT**  
Polarizer

Filter (ø45)

**U-LHLED100**  
High power LED lamp housing

**46S-LBA4**  
LBA filter

**BX3-SHT**  
Shutter for transmitted light

**BX3-RFAA\*4**  
Motorized fluorescence illuminator

**BX3-RFAS\*4**  
Coded fluorescence illuminator

**BX3-URA**  
Universal reflected illuminator

**BX3-25ND6**  
ND filter  
**BX3-25ND25**  
ND filter

**U-FMP**  
Mechanical stage

**U-CST**  
Centering target

**U-HLD-4, U-HLDT-4**  
Specimen holder

**U-HRD-4, U-HRDT-4**  
Specimen holder

**U-HLS-4, U-HLST-4**  
Specimen holder

**CX3-SHP**  
Specimen hold plate

**BX3-SHEA**  
Stage handle extension Adapter

**U-SRG2**  
Rotatable graduated stage

**U-SRP**  
Precision rotatable stage

**U-SP**  
Plain stage

**U-SHG**  
Rubber grip  
**U-SHGT**  
Rubber grip

**U-SVRO**  
Oil rectangular stage with right-hand control

**U-SVLO**  
Oil rectangular stage with left-hand control

**U-SVRB-4**  
Mechanical stages with right-hand control

**U-SVLB-4**  
Mechanical stages with left-hand control

\*1 Slight vignetting may occur in combination with an additional intermediate attachment or observation method. \*2 Require an additional intermediate attachment or fluorescence illuminator. \*3 Cannot be used with U-TTLBI. \*4 Compatible with FN 22. \*5 Cannot be used with BX3-URA. \*6 Stand is a standard equipment of the U-MDOSV, BX3-MDO18R, and U-MDO10R3.



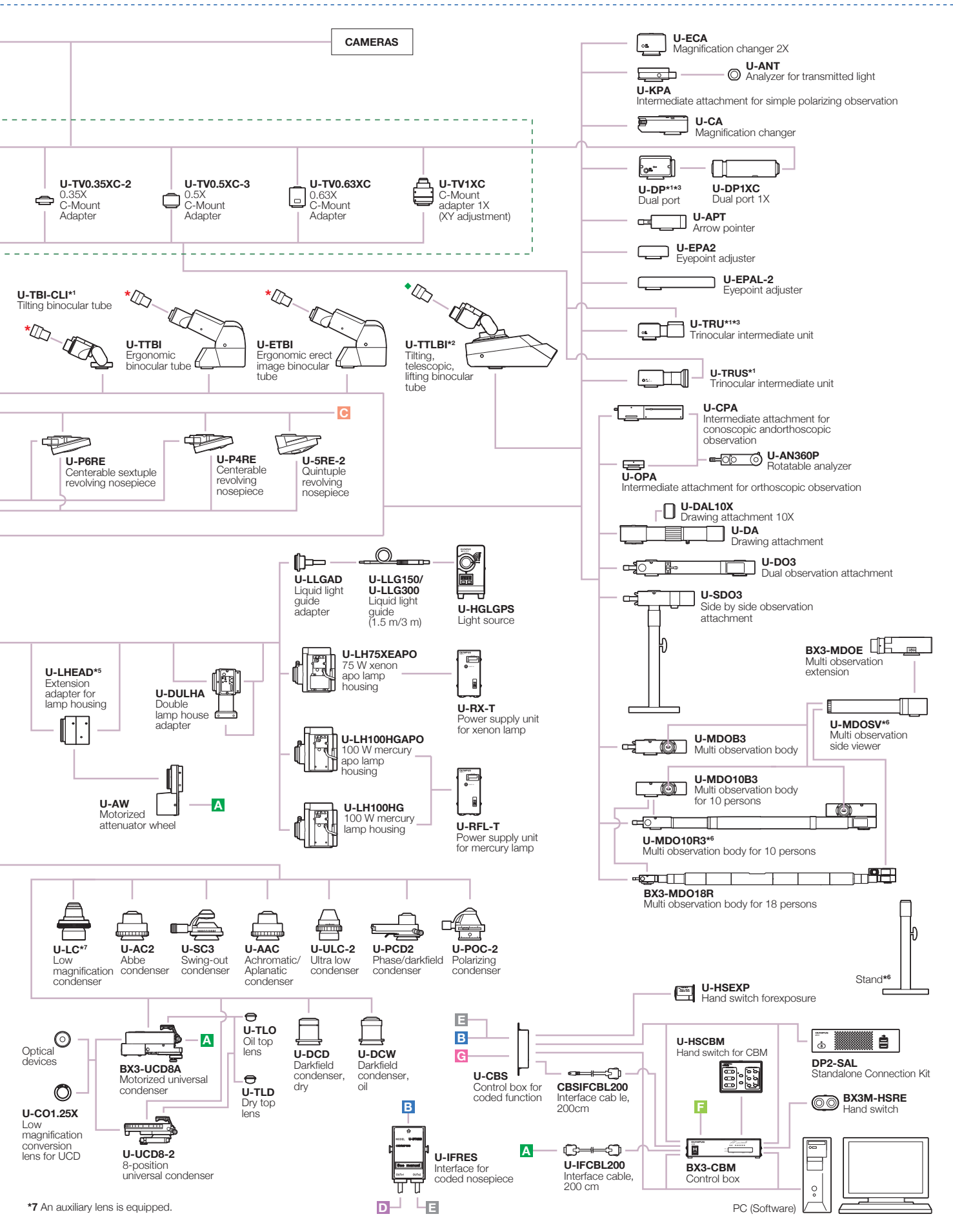

### BX63 specifications

Microscope frame	Optical system	UIS2 optical system
	Focus	Built-in motorized nosepiece focus Stroke: 20 mm; minimum increment: 0.01 $\mu\text{m}$ ; maximum nosepiece movement speed: 5 mm/s
	Illuminator	Built-in Köhler illumination for transmitted light, light intensity LED indicator, built-in motorized field stop • High color reproductivity LED light source • 12 V 100 W halogen bulb (pre-centered)
Revolving nosepiece		• Motorized septuple revolving nosepiece • Interchangeable reversed coded sextuple/coded septuple nosepiece
Observation tube	Widefield (FN 22)	• Widefield tilting trinocular • Widefield trinocular • Widefield erect image trinocular • Widefield tilting binocular • Widefield tilting, telescopic, lifting binocular • Widefield ergo binocular • Widefield binocular
Stage		• Ultrasonic stage (Stage stroke: X: 76 mm $\times$ Y: 52 mm; maximum stage movement speed: 30 mm/s • Ceramic-coated coaxial stage with left or right hand low drive control: with rotating mechanism and torque adjustment mechanism, optional rubber grips, and available stage handle extension adaptor • Cross stage with short left handle
Condenser		• Motorized universal condenser (NA 0.9, motorized 8-position turret, aperture stop, polarizing filter in/out mechanism, and top lens swing out mechanism), for 1.25X–100X [swing-out 1.25X-4X, with oil top lens: (NA 1.4)] • Swing out Achromatic (NA 0.9), for 1.25X–100X (swing-out: 1.25X–4X) • Achromatic Aplanatic (NA 1.4), for 10X–100X • Universal (NA 0.9), for 1.25X–100X [swing-out: 1.25X–4X, with oil top lens: (NA 1.4)] • Ultra low (NA 0.16), for 1.25X–4X • Darkfield dry (NA 0.8–0.92), for 10X–100X • Darkfield oil (NA 1.20–1.40), for 10X–100X
ND filter wheel		• Motorized 6-position ND filter wheel
Fluorescence illuminator		• Motorized multi-purpose coded type (FN 22, motorized 8-position mirror unit turret, 4-position ND slider) • Multi-purpose coded type (FN 22, 8-position mirror unit turret, 4-position ND slider)
Fluorescence light source		• 130 W Hg light guide illumination • 100 W Hg apo lamp housing and transformer • 100 W Hg lamp housing and transformer • 75 W Xe lamp housing and transformer
Controller		• High-performance control box ( I/F: FireWire)

### BX53 specifications

Microscope frame	Optical system	UIS2 optical system
	Focus	Vertical stage movement: 25 mm stage stroke with coarse adjustment limit stopper; torque adjustment for coarse adjustment knobs; stage mounting position variable; high sensitivity fine focusing knob (minimum adjustment gradations: 1 $\mu\text{m}$ )
	Illuminator	Built-in Köhler illumination for transmitted light, light preset switch, light intensity manager switch, high color reproductivity LED light source
Revolving nosepiece		Interchangeable reversed quintuple/coded quintuple/sextuple/septuple/coded sextuple/coded septuple nosepiece
Observation tube	Widefield (FN 22)	• Widefield tilting, telescopic and lifting binocular • Widefield tilting trinocular • Widefield trinocular • Widefield erect image trinocular • Widefield tilting binocular • Widefield tilting, telescopic, lifting binocular tube • Widefield ergo binocular • Widefield binocular
	Super widefield (FN 26.5)	• Super widefield trinocular • Super widefield erect image tilting trinocular
Stage		Ceramic-coated coaxial stage with left or right hand low drive control: with rotating mechanism and torque adjustment mechanism, optional rubber , light intensity manager switch, high color reproductivity LED light source available (non-stick grooved coaxial, plain, rotatable stages are also available)
Condenser		• Abbe (NA 1.1), for 4X–100X • Swing out Achromatic (NA 0.9), for 1.25X–100X (swing-out: 1.25X–4X) • Achromatic Aplanatic (NA 1.4), for 10X–100X • Phase contrast, darkfield (NA 1.1), [phase contrast: for 10X–100X, darkfield: for 10X–100X (up to NA 0.80)] • Universal (NA 0.9), for 1.25X–100X [swing-out: 1.25X–4X, with oil top lens: (NA 1.4)] • Low (NA 0.75), for 2X–100X (Dry) • Ultra low (NA 0.16), for 1.25X–4X • Darkfield dry (NA 0.8–0.92), for 10X–100X • Darkfield oil (NA 1.20–1.40), for 10X–100X
Fluorescence illuminator		• Multi-purpose coded type (FN 22, 8-position mirror unit turret, 4-position ND slider) • Economical type (FN 26.5, 8-position mirror unit turret)
Fluorescence light source		• 130 W Hg light guide illumination • 100 W Hg apo lamp housing and transformer • 100 W Hg lamp housing and transformer • 75 W Xe lamp housing and transformer

### BX63/BX53 common specifications

Operating environment	<ul style="list-style-type: none"> <li>• Indoor use</li> <li>• Ambient temperature : 5 °C to 40 °C (41 °F to 104 °F)</li> <li>• Maximum relative humidity : 80% for temperatures up to 31 °C (88 °F), decreasing linearly through 70% at 34 °C (93 °F), 60% at 37 °C (99 °F), to 50% relative humidity at 40 °C (104 °F)</li> <li>• Supply voltage fluctuations : Not to exceed <math>\pm 10\%</math> of the normal voltage</li> </ul>
-----------------------	--

**BX63 FL DIMENSIONS**

(unit: mm)

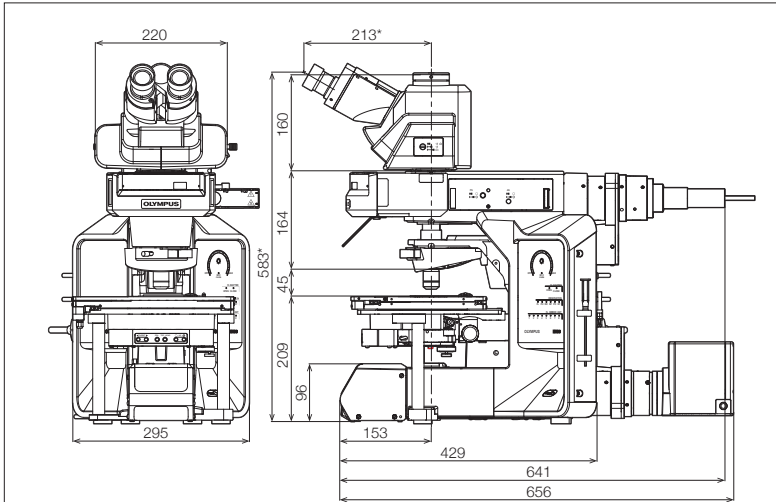

Weight: Approx. 33 kg, Power consumption: Approx. 450 W  
The length marked with an asterisk (\*) may vary according to interpupillary distance. Distance for figure shown is 62 mm.

**TOUCH PANEL CONTROLLER DIMENSIONS**

(unit: mm)

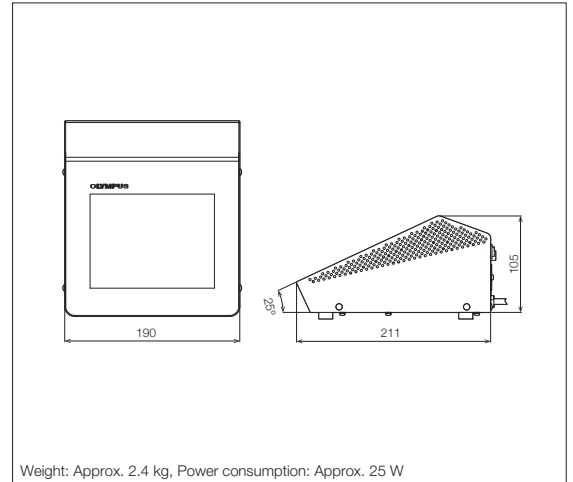

Weight: Approx. 2.4 kg, Power consumption: Approx. 25 W

**BX53 FL DIMENSIONS**

(unit: mm)

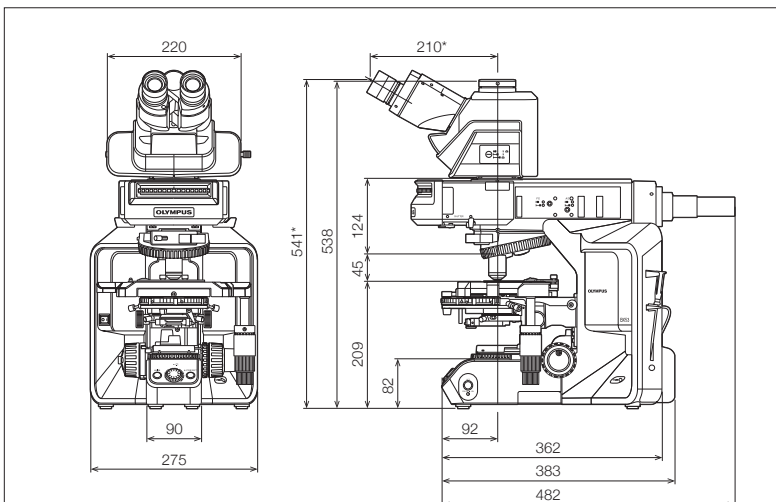

Weight: Approx. 19 kg, Power consumption: Approx. 330 W  
The length marked with an asterisk (\*) may vary according to interpupillary distance. Distance for figure shown is 62 mm.

**BX3-CBH DIMENSIONS**

(unit: mm)

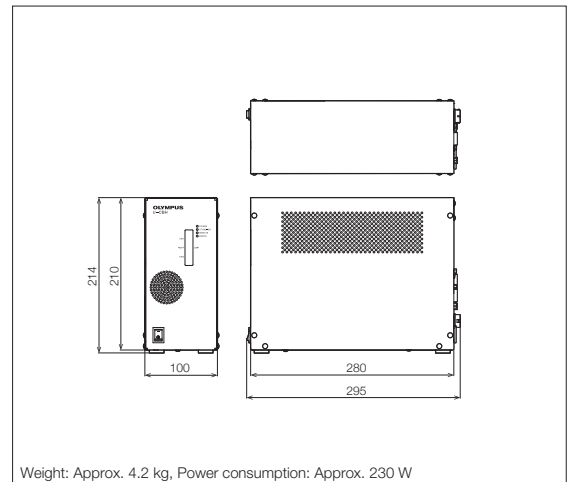

Weight: Approx. 4.2 kg, Power consumption: Approx. 230 W

**BX53 DIMENSIONS**

(unit: mm)

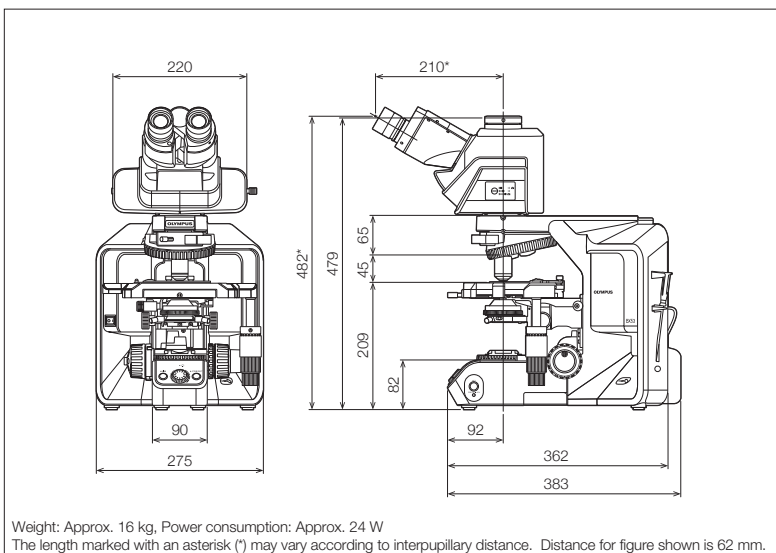

Weight: Approx. 16 kg, Power consumption: Approx. 24 W  
The length marked with an asterisk (\*) may vary according to interpupillary distance. Distance for figure shown is 62 mm.

 **MACROSEARCH**  
YOUR SINGLE SOURCE OF PATHOLOGY AND MICROSCOPY

Calle 103 No. 45 A - 29  
Tel.: 57-1-610.7261  
57-1-600.2126  
57-1-300.3154  
BOGOTA-COLOMBIA

[www.macrosearch.com.co](http://www.macrosearch.com.co)  
[macrosearch@macrosearch.com.co](mailto:macrosearch@macrosearch.com.co)

[www.olympus-lifescience.com](http://www.olympus-lifescience.com)

**OLYMPUS**<sup>®</sup>

**OLYMPUS CORPORATION**  
Shinjuku Monolith, 2-3-1 Nishi-Shinjuku, Shinjuku-ku, Tokyo 163-0914, Japan

**Images are courtesy of:**

Hiroo Ueno, Ph.D.  
Department of Stem Cell Pathology, Kansai Medical University  
(P.3, P.15 lower)

Dr. Shigeo Hayashi, Dr. Kagayaki Kato, Dr. Reiko Tajiri and Mr. Hosei Wada  
Laboratory for Morphogenetic Signaling  
RIKEN Center for Developmental Biology  
(P.12, P.16 top left)

Shigenobu Yonemura, Ph.D.  
Electron Microscope Laboratory  
RIKEN Center for Developmental Biology  
(P.15 top right, P.17 Phase contrast, P.19 middle)

Guojun Sheng, Ph.D., Yukiko Nakaya, Ph.D.  
Laboratory for Early Embryogenesis  
RIKEN Center for Developmental Biology  
(P.2, P.16 lower left)

Fumio Matsuzaki, Ph.D., Daijiro Konno, Ph.D.  
Laboratory for Cell Asymmetry  
RIKEN Center for Developmental Biology  
(P.15 top left, P.16 top right)

Junko Kyozuka, Associate Professor  
Graduate School of Agricultural and Life Sciences  
The Tokyo University  
(P.16 lower right)

- **OLYMPUS CORPORATION is ISO14001 certified.**
- **OLYMPUS CORPORATION is ISO9001 certified.**
- **OLYMPUS CORPORATION is ISO13485 certified.**
- **Illumination devices for microscope have suggested lifetimes. Periodic inspections are required. Please visit our website for details.**

• All company and product names are registered trademarks and/or trademarks of their respective owners.  
• Images on the PC monitors are simulated.  
• Specifications and appearances are subject to change without any notice or obligation on the part of the manufacturer.